

WDM SFP+ модули предназначены для создания каналов связи по одноволоконному SM кабелю на расстояние до 20км.

**Особенности:**

- 1270/1330нм DFB лазер
- возможность горячей замены
- LC разъем
- температурный диапазон от -5 до +70°C
- диагностика в соответствии со спецификацией MSA на SFP+

**Области применения:**

- 10GBASE-LR/EW 10G Ethernet
- 1200-SM-LL-L 10G Fiber Channel

**Absolute Maximum Ratings**

Parameter	Symbol	Min.	Max.	Unit
Storage Temperature	$T_s$	-40	+85	°C
Supply Voltage	$V_{CC}$	-0.5	3.6	V

**Recommended Operating Conditions**

Parameter	Symbol		Min.	Typical	Max.	Unit
Operating Case Temperature	$T_A$	SFP-Plus-WDM-1270-1330.20 SFP-Plus-WDM-1330-1270.20	-5		+70	°C
Power Supply Voltage	$V_{CC}$		3.15	3.3	3.45	V
Power Supply Current	$I_{CC}$				300	mA
Surge Current	$I_{Surge}$				+30	mA
Baud Rate				10.3125	10.5	GBaud

**PERFORMANCE SPECIFICATIONS - ELECTRICAL**

Parameter	Symbol	Min.	Typ.	Max	Unit	Notes
<b>TRANSMITTER</b>						
CML Inputs(Differential)	$V_{in}$	150		1200	mVp	AC coupled inputs
Input Impedance (Differential)	$Z_{in}$	85	100	115	ohms	$R_{in} > 100 \text{ kohms @ DC}$
Tx_DISABLE Input Voltage - High		2		$V_{CC}+0.3$	V	
Tx_DISABLE Input Voltage - Low		0		0.8	V	
Tx_FAULT Output Voltage -- High		2		$V_{CC}+0.3$	V	$I_o = 400\mu A$ ; Host $V_{CC}$
Tx_FAULT Output Voltage -- Low		0		0.5	V	$I_o = -4.0mA$
<b>RECEIVER</b>						
CML Outputs (Differential)	$V_{out}$	350		700	mVpp	AC coupled outputs

Output Impedance (Differential)	Zout	85	100	115	ohms	
Rx_LOS Output Voltage - High		2		V <sub>cc</sub> +0.3	V	I <sub>o</sub> = 400μA; Host V <sub>cc</sub>
Rx_LOS Output Voltage - Low		0		0.8	V	I <sub>o</sub> = -4.0mA
MOD_DEF ( 0:2 )	VoH	2.5			V	With Serial ID
	VoL	0		0.5	V	

**SFP-Plus-WDM-1270-1330.20 Optical and Electrical Characteristics**

Parameter	Symbol	Min.	Typical	Max.	Unit
9μm Core Diameter SMF			20		km
Data Rate			9.953/10.3125		Gbps
<b>Transmitter</b>					
Centre Wavelength	λ <sub>c</sub>	1260	1270	1280	nm
Spectral Width (-20dB)	Δλ			1	nm
Average Output Power <sup>*note4</sup>	P <sub>out,AVG</sub>	-2		2	dBm
Extinction Ratio	ER	3.5			dB
Side Mode Suppression Ratio	SMSR	30			dB
Transmitter and Dispersion Penalty	TDP			2	dB
Average Power of OFF Transmitter				-30	dBm
Relative Intensity Noise	RIN			-128	dB/Hz
Input Differential Impedance	Z <sub>IN</sub>	90	100	110	Ω
TX Disable	Disable		2.0	V <sub>cc</sub> +0.3	V
	Enable		0	0.8	
TX Fault	Fault		2.0	V <sub>cc</sub> +0.3	V
	Normal		0	0.8	
TX Disable Assert Time	t <sub>off</sub>			10	us
<b>Receiver</b>					
Centre Wavelength	λ <sub>c</sub>	1320		1340	nm
Sensitivity <sup>*note5</sup>	PIN			-14	dBm
Receiver Overload	P <sub>MAX</sub>	0.5			dBm
Output Differential Impedance	P <sub>IN</sub>	90	100	110	Ω
LOS De-Assert	LOS <sub>D</sub>			-18	dBm
LOS Assert	LOS <sub>A</sub>	-30			dBm
LOS	High		2.0	V <sub>cc</sub> +0.3	V
	Low		0	0.8	

**SFP-Plus-WDM-1330-1270.20 Optical and Electrical Characteristics**

Parameter	Symbol	Min.	Typical	Max.	Unit
9μm Core Diameter SMF			20		km
Data Rate			9.953/10.3125		Gbps
<b>Transmitter</b>					
Centre Wavelength	λ <sub>c</sub>	1320	1330	1340	nm
Spectral Width (-20dB)	Δλ			1	nm
Average Output Power <sup>*note4</sup>	P <sub>out,AVG</sub>	-2		2	dBm
Extinction Ratio	ER	3.5			dB

Side Mode Suppression Ratio		SMSR	30			dB
Transmitter and Dispersion Penalty		TDP			2	dB
Average Power of OFF Transmitter					-30	dBm
Relative Intensity Noise		RIN			-128	dB/Hz
Input Differential Impedance		Z <sub>IN</sub>	90	100	110	Ω
TX Disable	Disable		2.0		V <sub>CC</sub> +0.3	V
	Enable		0		0.8	
TX Fault	Fault		2.0		V <sub>CC</sub> +0.3	V
	Normal		0		0.8	
TX Disable Assert Time		t <sub>off</sub>			10	us
<b>Receiver</b>						
Centre Wavelength		λ <sub>C</sub>	1260		1280	nm
Sensitivity <sup>*note5</sup>		PIN			-14	dBm
Receiver Overload		P <sub>MAX</sub>	0.5			dBm
Output Differential Impedance		P <sub>IN</sub>	90	100	110	Ω
LOS De-Assert		LOS <sub>D</sub>			-18	dBm
LOS Assert		LOS <sub>A</sub>	-30			dBm
LOS	High		2.0		V <sub>CC</sub> +0.3	V
	Low		0		0.8	

\*Note4: Output is coupled into a 9/125um SMF.

\*Note5: Measured with worst ER, BER less than 1E-12 and PRBS 2<sup>31</sup>-1 at 10.3125Gbps.

### Pin Function Definitions

Pin Num.	Name	FUNCTION	Plug	Notes
1	VeeT	Transmitter Ground	1	
2	TX Fault	Transmitter Fault Indication	3	Note 1
3	TX Disable	Transmitter Disable	3	Note 2, Module disables on high or open
4	SDA	Module Definition 2	3	Note 3, Data line for Serial ID.
5	SCL	Module Definition 1	3	Note 3, Clock line for Serial ID.
6	MOD-ABS	Module Definition 0	3	Note 3
7	RS0	RX Rate Select (LVTTTL).	3	This pin has an internal 30k pull down to ground. A signal on this pin will not affect module performance.
8	LOS	Loss of Signal	3	Note 4
9	RS1	TX Rate Select (LVTTTL).	1	This pin has an internal 30k pull down to ground. A signal on this pin will not affect module performance.
10	VeeR	Receiver Ground	1	Note 5
11	VeeR	Receiver Ground	1	Note 5
12	RD-	Inv. Received Data Out	3	Note 6
13	RD+	Received Data Out	3	Note 7
14	VeeR	Receiver Ground	1	Note 5

15	VccR	Receiver Power	2	3.3 ± 5%, Note 7
16	VccT	Transmitter Power	2	3.3 ± 5%, Note 7
17	VeeT	Transmitter Ground	1	Note 5
18	TD+	Transmit Data In	3	Note 8
19	TD-	Inv. Transmit Data In	3	Note 8
20	VeeT	Transmitter Ground	1	Note 5

**Notes:**

1) TX Fault is an open collector/drain output, which should be pulled up with a 4.7K – 10KΩ resistor on the host board. Pull up voltage between 2.0V and VccT, R+0.3V. When high, output indicates a laser fault of some kind. Low indicates normal operation. In the low state, the output will be pulled to < 0.8V.

2) TX disable is an input that is used to shut down the transmitter optical output. It is pulled up within the module with a 4.7 – 10 K Ω resistor. Its states are:

Low (0 – 0.8V): Transmitter on

(>0.8, < 2.0V): Undefined

High (2.0 – 3.465V): Transmitter Disabled

Open: Transmitter Disabled

3) Modulation Absent, connected to VEET or VEER in the module.

4) LOS (Loss of Signal) is an open collector/drain output, which should be pulled up with a 4.7K – 10KΩ resistor. Pull up voltage between 2.0V and VccT, R+0.3V. When high, this output indicates the received optical power is below the worst-case receiver sensitivity (as defined by the standard in use). Low indicates normal operation. In the low state, the output will be pulled to < 0.8V.

5) VeeR and VeeT may be internally connected within the SFP+ module.

6) RD-/+ : These are the differential receiver outputs. They are AC coupled 100Ω differential lines which should be terminated with 100Ω (differential) at the user SERDES. The AC coupling is done inside the module and is thus not required on the host board. The voltage swing on these lines will be between 370 and 2000 mV differential (185 –1000 mV single ended) when properly terminated.

7) VccR and VccT are the receiver and transmitter power supplies. They are defined as 3.3V ±5% at the SFP+ connector pin. Maximum supply current is 300mA. Recommended host board power supply filtering is shown below. Inductors with DC resistance of less than 1 ohm should be used in order to maintain the required voltage at the SFP+ input pin with 3.3V supply voltage. When the recommended supply-filtering network is used, hot plugging of the SFP+ transceiver module will result in an inrush current of no more than 30mA greater than the steady state value. VccR and VccT may be internally connected within the SFP+ transceiver module.

8) TD-/+ : These are the differential transmitter inputs. They are AC-coupled, differential lines with 100Ω

differential termination inside the module. The AC coupling is done inside the module and is thus not required on the host board. The inputs will accept differential swings of 500 – 2400 mV (250 – 1200mV single-ended), though it is recommended that values between 500 and 1200 mV differential (250 – 600mV single-ended) be used for best EMI performance.

**EEPROM**

The serial interface uses the 2-wire serial CMOS EEPROM protocol defined for the ATMEL AT24C02/04 family of components. When the serial protocol is activated, the host generates the serial clock signal (SCL). The positive edge clocks data into those segments of the EEPROM that are not write protected within the SFP+ transceiver. The negative edge clocks data from the SFP+ transceiver. The serial data signal (SDA) is bi-directional for serial data transfer. The host uses SDA in conjunction with SCL to mark the start and end of serial protocol activation. The memories are organized as a series of 8-bit data words that can be addressed individually or sequentially.

The Module provides diagnostic information about the present operating conditions. The transceiver generates this diagnostic data by digitization of internal analog signals. Calibration and alarm/warning threshold data is written during device manufacture. Received power monitoring, transmitted power monitoring, bias current monitoring, supply voltage monitoring and temperature monitoring all are implemented. The diagnostic data are raw A/D values and must be converted to real world units using calibration constants stored in EEPROM locations 56 – 95 at wire serial bus address A2h. The digital diagnostic memory map specific data field define as following.

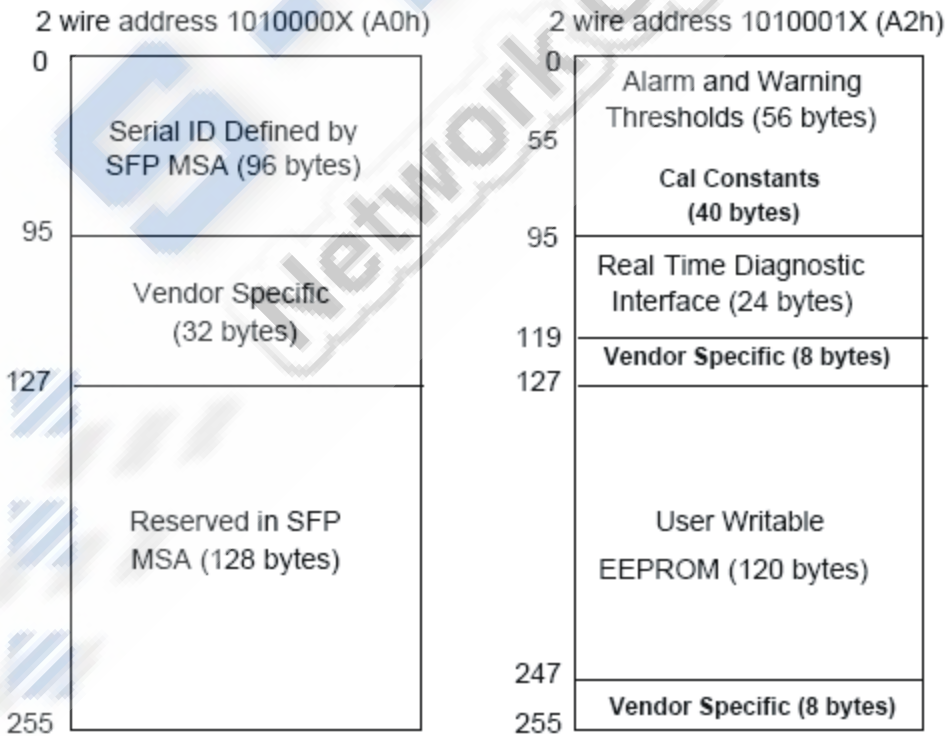

Mechanical Specifications

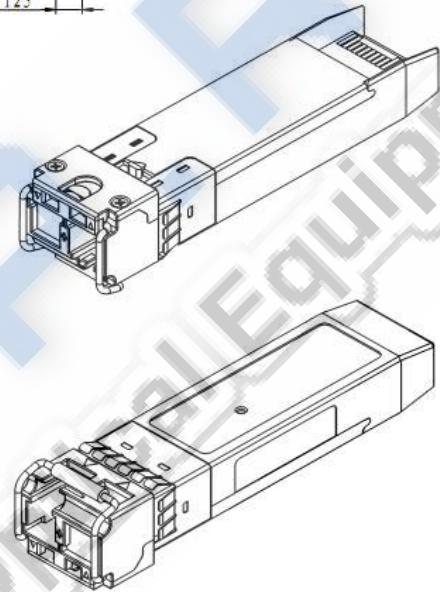
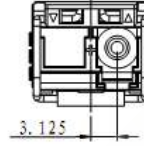
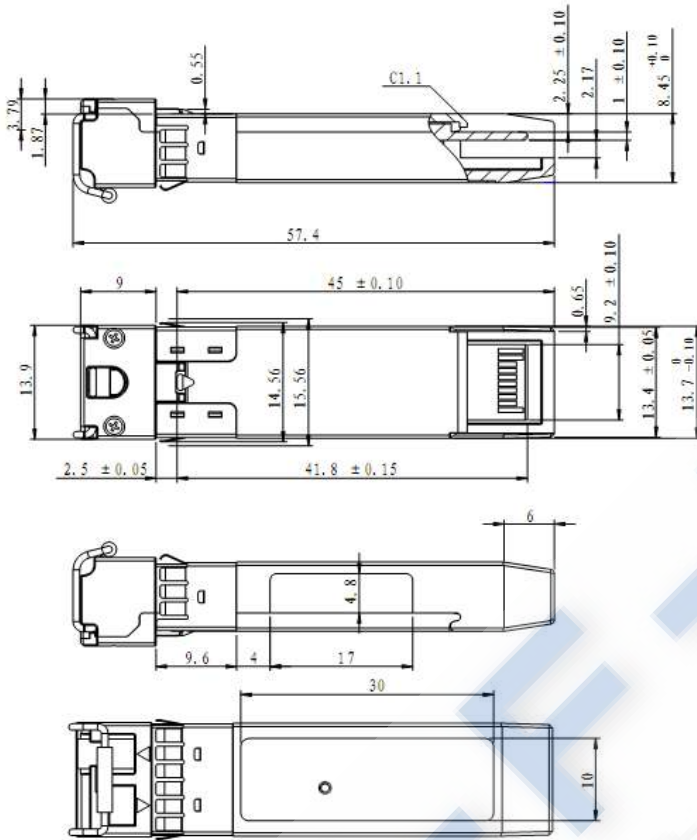

Network Equipment

