

QPS-2102MWG

(RoHS Compliant)

40G / 1.4km / 1310 nm QSFP+ MPO SINGLE-MODE Optical Transceiver

FEATURES

- Up to 11.2 Gbps Data Links Per Lane
- Compliant with SFF-8436 QSFP+ MSA
- Link Length up to 1.4km with SMF
- 2-Wire Interface for Integrated Digital Diagnostic Monitoring
- Power Consumption < 2W
- Single +3.3V Power Supply
- RoHS Compliant
- 0 to 70°C Case Operating Temperature
- MPO optical Connector (IEC61754-7-1)

APPLICATIONS

- Datacenter and enterprise networking
- Switch Router and HBAs
- 40G Ethernet
- Infiniband QDR, DDR and SDR
- High-performance backplane

DESCRIPTION

QPS-2102MWG series single mode QSFP+ transceiver is designed for single-mode fiber optical data communications such as 40GBASE-PSM4.

The transceiver consists of two sections: The transmitter section consists of four directly modulated uncooled 1310 nm DFB lasers and four drivers. The receiver section incorporates four PIN photodiodes integrated with four trans-impedance preamplifiers (TIA) and four limiting post-amplifier ICs.

The module is with the QSFP+ 38-pin connector to allow hot plug capability. The internally ac coupled high speed serial I/O simplifies interfacing to external circuitry. Only single 3.3V power supply is needed.

A serial EEPROM in the transceiver allows the user to access transceiver digital diagnostic monitoring and configuration data via the 2-wire QSFP+ Management Interface. This interface uses a single address, A0h, with a memory map divided into a lower and upper area. Basic digital diagnostic data is held in the lower area while specific data is held in a series of tables in the high memory area.

LASER SAFETY

This single mode transceiver is a Class 1 laser product. It complies with IEC-60825-1 and FDA 21 CFR 1040.10 and 1040.11. The transceiver must be operated within the specified temperature and voltage limits. The optical ports of the module shall be terminated with an optical connector or with a dust plug.

ORDER INFORMATION

P/No.	Bit Rate (Gb/s)	Package	Connector	Temp (°C)	RoHS Compliant
QPS-2102MWG	41.25	QSFP+ with DMI	MPO	0 to 70	Yes

Absolute Maximum Ratings

Parameter	Symbol	Min	Max	Units	Notes
Storage Temperature	Tstg	-40	85	°C	
Operating Case Temperature	Topr	0	70	°C	
Relative Humidity	RH	5	85	%	Non condensing
Power Supply Voltage	V _{CC}	0	3.8	V	

Recommended Operating Conditions

Parameter	Symbol	Min	Typ	Max	Units / Notes
Power Supply Voltage	V _{CC}	3.15	3.3	3.45	V
Power Supply Current	I _{CC}			600	mA
Power Dissipation	P _D			2	W
Operating Case Temperature	Topr	0		70	°C
Lane Rate			10.3125		Gb/s

Transmitter Optical Specifications (Topr= 0 to 70°C, Vcc3 = 3.3V ±5%)						
Parameter	Symbol	Min	Typ	Max	Units	Notes
Average Launch Power, each lane	PO, Avg	-8.2		0.5	dBm	1
Launch Power in OMA, each lane	PO, OMA	-5.2		2.0	dBm	
Difference in launch power between any two lanes in OMA	Ptx, diff			5.0	dB	
Center Wavelength, each lane	λ_{CO}	1260		1360	nm	
Side Mode Suppression Ratio	SMSR	30			dB	
Extinction Ratio	ER	3.5			dB	
Transmitter and Dispersion Penalty	TDP			2.6	dB	
Launch power in OMA minus TDP	Tx-TDP	-9.7			dBm	
Relative Intensity Noise	RIN			-128	dB/Hz	
Optical Return Loss Tolerance	TOL			12	dB	
Optical Eye Mask Margin	EMM	5			%	
Average Launch Power of OFF Transmitter				-30	dBm	

Receiver Optical Specifications (Topr= 0 to 70°C, Vcc3 = 3.3V ±5%)						
Parameter	Symbol	Min	Typ	Max	Units	Notes
Stress receiver sensitivity (OMA), each lane	Sen			-12.6	dBm	
Overload, each lane	OVL	0.5			dBm	
Damage Threshold		3	---		dBm	
LOS -- Deasserted	LOS _D	---	---	-15	dBm	Transition: low to high
LOS -- Asserted	LOS _A	-30	---	---	dBm	Transition: high to low
LOS -- Hysteresis		0.5	---	6	dB	
Wavelength of Operation – each lane	λ_{CO}	1260		1360	nm	

Electrical Characteristics						
Parameter	Symbol	Min	Typ	Max	Units	Notes
High-Speed Signal (CML) Interface Specification						
Input Data Rate			10.3125		Gps	
Differential Input Impedance	Rin	90	100	110	Ω	
Differential Data Input Amplitude		200		800	mVpp	Internally AC coupled
TP1/TP1a interface	Compliant to IEEE 802.3ba XLPP1					
Output Data Rate			10.3125		Gps	
Differential Output Impedance	Rout	90	100	110	Ω	
Differential Data Output Amplitude		400	600	850	mVpp	Internally AC coupled
TP4 Interface	Compliant to IEEE 802.3ba XLPP1					

CONNECTION DIAGRAM

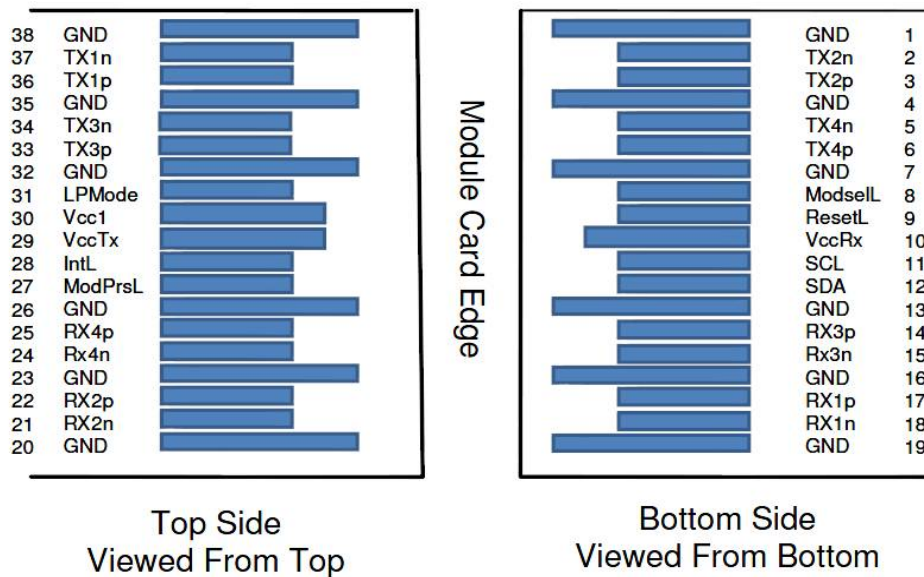
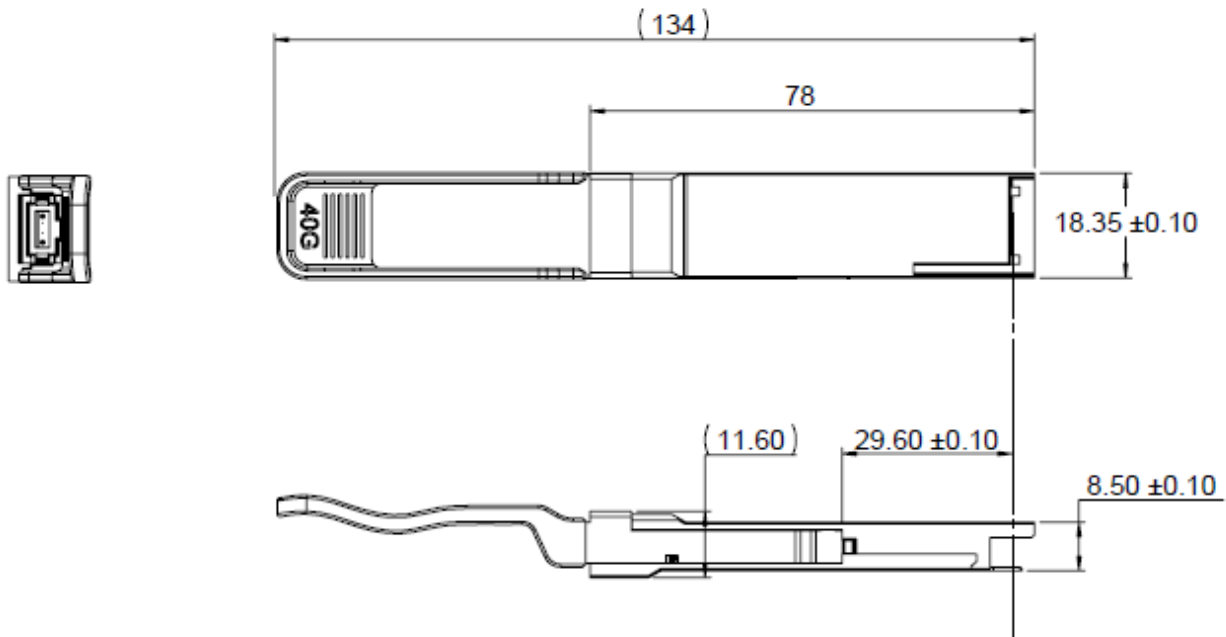

Table 3 PIN Description

PIN	Logic	Signal Name	Description	Note
1		GND	Ground	
2	CML-I	Tx2n	Transmitter Inverted Data Input	
3	CML-I	Tx2p	Transmitter Non-Inverted Data Input	
4		GND	Ground	
5	CML-I	Tx4n	Transmitter Inverted Data Input	
6	CML-I	Tx4p	Transmitter Non-Inverted Data Input	
7		GND	Ground	
8	LVTTL-I	ModSelL	Module Select	
9	LVTTL-I	ResetL	Module Reset	
10		Vcc Rx	+3.3V Power Supply Receiver	
11	LVC MOS-I/O	SCL	2-wire serial interface clock	
12	LVC MOS-I/O	SDA	2-wire serial interface data	
13		GND	Ground	
14	CML-O	Rx3p	Receiver Non-Inverted Data Output	
15	CML-O	Rx3n	Receiver Inverted Data Output	
16		GND	Ground	
17	CML-O	Rx1p	Receiver Non-Inverted Data Output	
18	CML-O	Rx1n	Receiver Inverted Data Output	
19		GND	Ground	
20		GND	Ground	
21	CML-O	Rx2n	Receiver Inverted Data Output	
22	CML-O	Rx2p	Receiver Non-Inverted Data Output	
23		GND	Ground	
24	CML-O	Rx4n	Receiver Inverted Data Output	
25	CML-O	Rx4p	Receiver Non-Inverted Data Output	
26		GND	Ground	
27	LVTTL-O	ModPrsL	Module Present	
28	LVTTL-O	IntL	Interrupt	
29		Vcc Tx	+3.3V Power supply transmitter	
30		Vcc1	+3.3V Power supply	
31	LVTTL-I	LPMode	Low Power Mode	

32		GND	Ground	
33	CML-I	Tx3p	Transmitter Non-Inverted Data Input	
34	CML-I	Tx3n	Transmitter Inverted Data Input	
35		GND	Ground	
36	CML-I	Tx1p	Transmitter Non-Inverted Data Input	
37	CML-I	Tx1n	Transmitter Inverted Data Input	
38		GND	Ground	

MECHANICAL SPECIFICATION (UNITS IN MM)



ATTENTION

To minimize MPO connection induced reflections, an MPO receptacle with 8-degree angled end-face is utilized for this product. A female MPO connector with 8-degree end-face should be used with this product as illustrated in below.

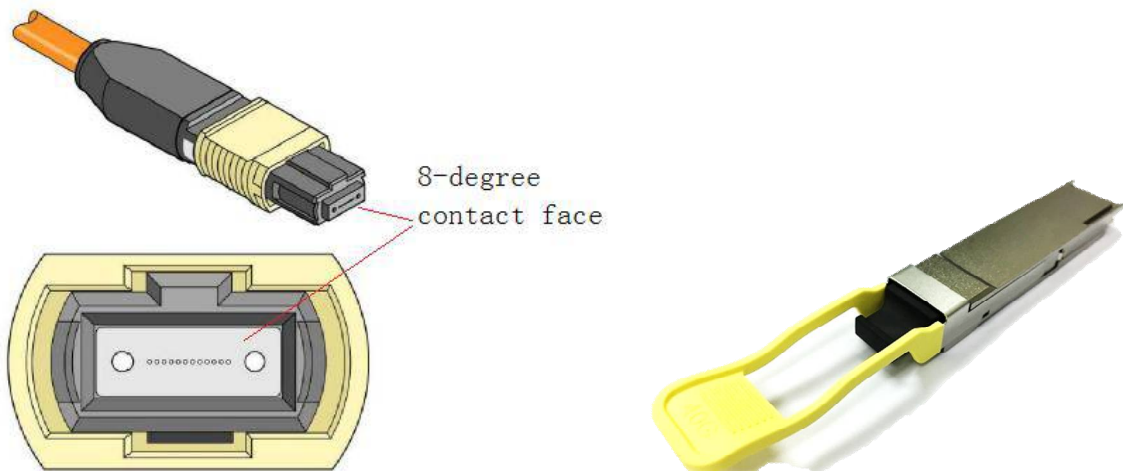

REVISION HISTORY

Version	Subject	Release Date
1.0	Initial datasheet	2019/3/15