

For LS38 series

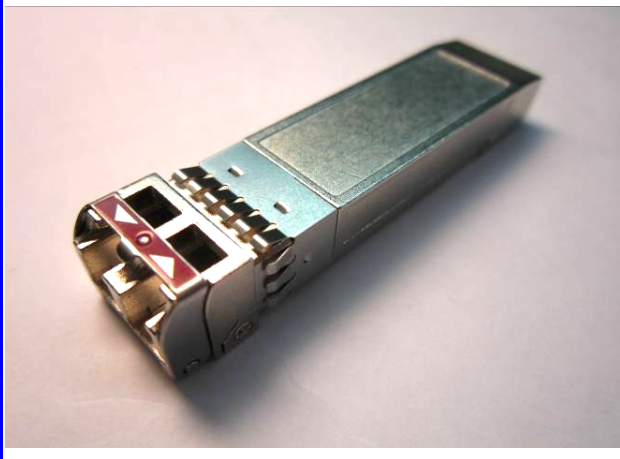

For LS48 series



### Features

---

- Compliant with SFP+ MSA SFF-8431
- Compliant with SFF8472 diagnostic monitoring interface Duplex LC connector
- Single power supply 3.3V
- Hot Pluggable
- Support 12G/6G/3G/HD/SD SDI application
- Supports video pathological patterns
- Supports video color bar patterns
- RoHS compliant



**1271~ 1611nm CWDM 10km Single-mode Transceiver  
Small Form Pluggable (SFP+), with Diagnostic Monitoring  
Support 12G/6G/3G/HD/SD SDI application**

**Ordering Information**

PART NUMBER	Wavelength	VOLTAGE	TEMPERATURE	Distance
LE38-H3S-TC-N-SA	1271	3.3V	0°C to 70°C	10km
LE38-H3S-TC-N-SB	1291	3.3V	0°C to 70°C	10km
LE38-H3S-TC-N-SC	1311	3.3V	0°C to 70°C	10km
LE38-H3S-TC-N-SD	1331	3.3V	0°C to 70°C	10km
LE38-H3S-TC-N-SE	1351	3.3V	0°C to 70°C	10km
LE38-H3S-TC-N-SF	1371	3.3V	0°C to 70°C	10km
LE38-H3S-TC-N-SG	1391	3.3V	0°C to 70°C	10km
LE38-H3S-TC-N-SH	1411	3.3V	0°C to 70°C	10km
LE38-H3S-TC-N-SI	1431	3.3V	0°C to 70°C	10km
LE38-H3S-TC-N-SJ	1451	3.3V	0°C to 70°C	10km
LE48-H3S-TC-N-SK	1471	3.3V	0°C to 70°C	10km
LE48-H3S-TC-N-SL	1491	3.3V	0°C to 70°C	10km
LE48-H3S-TC-N-SM	1511	3.3V	0°C to 70°C	10km
LE48-H3S-TC-N-SN	1531	3.3V	0°C to 70°C	10km
LE48-H3S-TC-N-SO	1551	3.3V	0°C to 70°C	10km
LE48-H3S-TC-N-SP	1571	3.3V	0°C to 70°C	10km
LE48-H3S-TC-N-SQ	1591	3.3V	0°C to 70°C	10km
LE48-H3S-TC-N-SR	1611	3.3V	0°C to 70°C	10km



**1271~ 1611nm CWDM 10km Single-mode Transceiver  
 Small Form Pluggable (SFP+), with Diagnostic Monitoring  
 Support 12G/6G/3G/HD/SD SDI application**

**Diagnostics**

Parameter	Range	Accuracy	Unit	Calibration
Internal Transceiver Temperature	-40 to 95	$\pm 3$	$^{\circ}\text{C}$	Internal
Internal Transceiver Voltage	3.1 to 3.5	$\pm 0.1$	V	
Bias Current	0 to 100	$\pm 10\%$	mA	
TX Power	+2 to +8	$\pm 3$	dB	
RX average Power	+2 to -10	$\pm 3$	dB	

**Absolute Maximum Ratings**

PARAMETER	SYMBOL	MIN	MAX	UNITS	NOTE
Storage Temperature	$T_S$	-40	85	$^{\circ}\text{C}$	
Supply Voltage	$V_{CC}$	-0.5	4.0	V	
Input Voltage	$V_{IN}$	-0.5	$V_{CC}$	V	

**Recommended Operating Conditions**

PARAMETER	SYMBOL	MIN	MAX	UNITS	NOTE
Case operating Temperature	$T_C$	0	70	$^{\circ}\text{C}$	
Supply Voltage	$V_{CC}$	3.14	3.46	V	
Supply Current	$I_{TX} + I_{RX}$		300	mA	
Power Consumption	$P$	---	1.0	W	



**1271~ 1611nm CWDM 10km Single-mode Transceiver  
Small Form Pluggable (SFP+), with Diagnostic Monitoring  
Support 12G/6G/3G/HD/SD SDI application**

**Transmitter Electro-optical Characteristics**

$V_{cc} = 3.14 \text{ V to } 3.46 \text{ V}, T_C = 0^\circ \text{C to } 70^\circ \text{C}$

PARAMETER	SYMBOL	MIN	TYP.	MAX	UNITS	NOTE
Data Rate	$B$	0.27	---	11.88	Gbps	
Output Optical Power	$P_{out}$	+1	---	+8	dBm	
Extinction Ratio	$ER$	4.0			dB	
Central Wavelength (-SA)		1263.5	---	1278.5	nm	
Central Wavelength (-SB)		1283.5	---	1298.5	nm	
Central Wavelength (-SC)		1303.5	---	1318.5	nm	
Central Wavelength (-SD)		1323.5	---	1338.5	nm	
Central Wavelength (-SE)		1343.5	---	1358.5	nm	
Central Wavelength (-SF)		1363.5	---	1378.5	nm	
Central Wavelength (-SG)		1383.5	---	1398.5	nm	
Central Wavelength (-SH)		1403.5	---	1418.5	nm	
Central Wavelength (-SI)	$\lambda_c$	1423.5	---	1438.5	nm	
Central Wavelength (-SJ)		1443.5	---	1458.5	nm	
Central Wavelength (-SK)		1463.5	---	1478.5	nm	
Central Wavelength (-SL)		1483.5	---	1498.5	nm	
Central Wavelength (-SM)		1503.5	---	1518.5	nm	
Central Wavelength (-SN)		1523.5	---	1538.5	nm	
Central Wavelength (-SO)		1543.5	---	1558.5	nm	
Central Wavelength (-SP)		1563.5	---	1578.5	nm	
Central Wavelength (-SQ)		1583.5	---	1598.5	nm	
Central Wavelength (-SR)		1603.5	---	1618.5	nm	
Spectrum Width	$\Delta \lambda$			1	nm	
Side mode Suppression ratio	$SSR_{min}$	30			dB	
Transmitter and Dispersion Penalty	$TDP$			2	dB	
Relative Intensity Noise	$RIN$	---	---	-128	dB/Hz	
Max. $P_{out}$ TX-DISABLE Asserted	$P_{OFF}$	---	---	-35	dBm	
Differential Input Impedance	$Z_d$	75	100	125	$\Omega$	



**1271~ 1611nm CWDM 10km Single-mode Transceiver  
Small Form Pluggable (SFP+), with Diagnostic Monitoring  
Support 12G/6G/3G/HD/SD SDI application**

---

Differential Input Voltage Swing	$V_{DIFF}$	200		800	mV
Transmit Fault Output-Low	$TX\_FAULT_L$	0.0	---	0.5	V
Transmit Fault Output-High	$TX\_FAULT_H$	2.4	---	$V_{CC}$	V
TX_DISABLE Assert Time	$t_{off}$	---	---	100	$\mu s$
TX_DISABLE Negate Time	$t_{on}$	---	---	2	ms
Time to initialize, include reset of TX_FAULT	$t_{init}$	---	---	300	ms
TX_FAULT from fault to assertion	$t_{fault}$	---	---	1	ms
TX_DISABLE time to start reset	$t_{reset}$	10	---	---	$\mu s$



**1271~ 1611nm CWDM 10km Single-mode Transceiver  
Small Form Pluggable (SFP+), with Diagnostic Monitoring  
Support 12G/6G/3G/HD/SD SDI application**

**Receiver Electro-optical Characteristics**

$V_{CC} = 3.14 \text{ V to } 3.46 \text{ V}, T_C = 0^\circ \text{C to } 70^\circ \text{C}$

PARAMETER	SYMBOL	MIN	TYP.	MAX	UNITS	NOTE
	L					
Data Rate	$B$	0.27	---	11.88	Gbps	
Optical Input Power	$P_{IN}$	-7	---	+0.5	dBm	BER < $10^{-12}$ <b>For</b> <b>(12G pathological)</b>
Optical Input Power	$P_{IN}$	-15	---	+0.5	dBm	BER < $10^{-12}$ <b>For</b> <b>(3G to SD pathological)</b>
Operating Center Wavelength	$\lambda_C$	1260	---	1620	nm	
Optical Return Loss	$ORL$	12	---	---	dB	
Loss of Signal-Asserted	$P_A$	-35	---	---	dBm	
Loss of Signal-Deasserted	$P_D$	---	---	-8	dBm	
Reference Differential Output Impedance	$Z_d$	---	100	---	$\Omega$	
Differential Output Voltage	$V_{DIFF}$	350	---	850	mV	
Receiver Loss of Signal Output Voltage-Low	$RX\_LO$ $S_L$	0	---	0.5	V	
Receiver Loss of Signal Output Voltage-High	$RX\_LO$ $S_H$	2.4	---	$V_{CC}$	V	
Receiver Loss of Signal Assert Time (off to on)	$t_{A,RX\_LOS}$	---	---	100	$\mu\text{s}$	
Receiver Loss of Signal Assert Time (on to off)	$t_{D,RX\_LOS}$	---	---	100	$\mu\text{s}$	



**1271~ 1611nm CWDM 10km Single-mode Transceiver  
Small Form Pluggable (SFP+), with Diagnostic Monitoring  
Support 12G/6G/3G/HD/SD SDI application**

**Digital Diagnostic Memory Map**

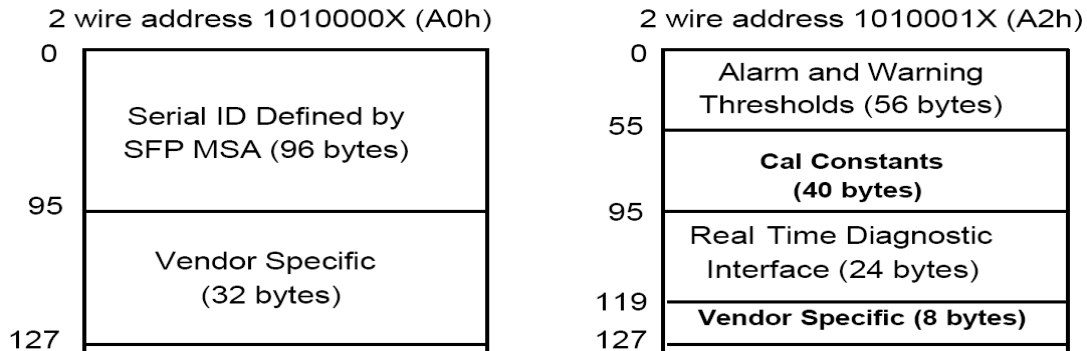

**EEPROM Serial ID Memory contents(A0h)**

Address	Hex	Fields	Result
0	03(H)	identifier	SFP or SFP+
1	04(H)	Ext.Identifier	GBIC/SFP function is defined by two-wire interface ID only
2	07(H)	Connector	LC
3	00(H)		Unallocated
4	00(H)		
5	00(H)		
6	00(H)		
7	00(H)		
8	00(H)		
9	00(H)		
10	00(H)		
11	06(H)	Encoding	64B/66B
12	77(H)	BR(Nominal)	11900Mbps
13	00(H)	Rate Identifier	Unspecified
14	0A(H)	Length(SMFm)-km	10(units of km)
15	64(H)	Length(SMF)	100(units of 100m)
16	00(H)	Length(50µm)	N/A
17	00(H)	Length(62.5µm)	N/A
18	00(H)	Length(cable)	N/A
19	00(H)	Length(OM3)	N/A
20	41(H)	Vendor name	A
21	50(H)	Vendor name	P
22	41(H)	Vendor name	A
23	43(H)	Vendor name	C
24	20(H)	Vendor name	
25	4F(H)	Vendor name	O
26	70(H)	Vendor name	p
27	74(H)	Vendor name	t



**1271~ 1611nm CWDM 10km Single-mode Transceiver  
Small Form Pluggable (SFP+), with Diagnostic Monitoring  
Support 12G/6G/3G/HD/SD SDI application**

28	6F(H)	Vendor name	0
29	20(H)	Vendor name	
30	20(H)	Vendor name	
31	20(H)	Vendor name	
32	20(H)	Vendor name	
33	20(H)	Vendor name	
34	20(H)	Vendor name	
35	20(H)	Vendor name	
36	00(H)	Transceiver	Unallocated
37	00(H)	Vendor OUI	0
38	0F(H)	Vendor OUI	0F
39	99(H)	Vendor OUI	99
40	4C(H)	Vendor PN	L
41	45(H)	Vendor PN	E
42	33(H)	Vendor PN	3
43	38(H)	Vendor PN	8
44	2D(H)	Vendor PN	-
45	48(H)	Vendor PN	H
46	33(H)	Vendor PN	3
47	53(H)	Vendor PN	S
48	2D(H)	Vendor PN	-
49	54(H)	Vendor PN	T
50	43(H)	Vendor PN	C
51	2D(H)	Vendor PN	-
52	4E(H)	Vendor PN	N
53	2D(H)	Vendor PN	-
54		Vendor PN	Refer to page 2
55		Vendor PN	
56	30(H)	Vendor rev	0
57	30(H)	Vendor rev	0
58	30(H)	Vendor rev	0
59	30(H)	Vendor rev	0
60		Wavelength	Refer to page 2
61		Wavelength	
62	00(H)	Unallocated	Unallocated
63		CC_BASE	
64	00(H)	Options	Unallocated
65	1A(H)	Options	Loss of Signal;Tx_Fault;Tx_Disable;
66	00(H)	BR	max
67	00(H)	BR	min
68		Vendor SN	
69			
70			
71			





**1271~ 1611nm CWDM 10km Single-mode Transceiver  
 Small Form Pluggable (SFP+), with Diagnostic Monitoring  
 Support 12G/6G/3G/HD/SD SDI application**

72			
73			
74			
75			
76			
77			
78			
79			
80			
81			
82			
83			
84		Date code	
85			
86			
87			
88			
89			
90			
91			
92	68(H)	Diagnostic Monitoring Type	Received Power Measurement Type;Internally Calibrated;Digital diagnostic monitoring implemented;
93	B0(H)	Enhanced Options	Rx_Loss Monitoring;Tx_Fault Monitoring;Alarm/warning Flags;
94	03(H)	SFF-8472 Compliance	includes functionality described in Rev 10.2 of SFF-8472
95		CC_EXT	
96	45(H)	Vendor Specific	E
97	58(H)	Vendor Specific	X
98	54(H)	Vendor Specific	T
99	52(H)	Vendor Specific	R
100	45(H)	Vendor Specific	E
101	4D(H)	Vendor Specific	M
102	45(H)	Vendor Specific	E
103	4C(H)	Vendor Specific	L
104	59(H)	Vendor Specific	Y
105	20(H)	Vendor Specific	
106	43(H)	Vendor Specific	C
107	4F(H)	Vendor Specific	O
108	4D(H)	Vendor Specific	M
109	50(H)	Vendor Specific	P
110	41(H)	Vendor Specific	A
111	54(H)	Vendor Specific	T
112	49(H)	Vendor Specific	I



**1271~ 1611nm CWDM 10km Single-mode Transceiver  
Small Form Pluggable (SFP+), with Diagnostic Monitoring  
Support 12G/6G/3G/HD/SD SDI application**

113	42(H)	Vendor Specific	B
114	4C(H)	Vendor Specific	L
115	45(H)	Vendor Specific	E
116	20(H)	Vendor Specific	
117	20(H)	Vendor Specific	
118	20(H)	Vendor Specific	
119	20(H)	Vendor Specific	
120	20(H)	Vendor Specific	
121	20(H)	Vendor Specific	
122	20(H)	Vendor Specific	
123	20(H)	Vendor Specific	
124	20(H)	Vendor Specific	
125	20(H)	Vendor Specific	
126	20(H)	Vendor Specific	
127	20(H)	Vendor Specific	

**EEPROM Serial ID Memory contents (A2h)**

For  $T_C = 0^{\circ}\text{C}$  to  $70^{\circ}\text{C}$

Address(A2h)	Description	Value
00-01	Temp High Alarm	80 Degree C
02-03	Temp Low Alarm	-10 Degree C
04-05	Temp High Warning	75 Degree C
06-07	Temp Low Warning	-5 Degree C
08-09	Voltage High Alarm	3.6 V
10-11	Voltage Low Alarm	2.3 V
12-13	Voltage High Warning	3.5 V
14-15	Voltage Low Warning	2.4 V
16-17	Bias High Alarm	80 mA
18-19	Bias Low Alarm	0.1 mA
20-21	Bias High Warning	70 mA
22-23	Bias Low Warning	0.5 mA
24-25	TX Power High Alarm	+8dBm
26-27	TX Power Low Alarm	0 dBm
28-29	TX Power High Warning	+8dBm
30-31	TX Power Low Warning	+1 dBm
32-33	RX Power High Alarm	+1 dBm
34-35	RX Power Low Alarm	-10 dBm
36-37	RX Power High Warning	0 dBm
38-39	RX Power Low Warning	-8 dBm
40-55	Reserved Reserved for future monitored quantities	
56-91	External calibration constant	
92-94	Reserved	
95	Check sum	
96-97	Real Time temperature	



**1271~ 1611nm CWDM 10km Single-mode Transceiver  
 Small Form Pluggable (SFP+), with Diagnostic Monitoring  
 Support 12G/6G/3G/HD/SD SDI application**

98-99	Real Time supply voltage	
100-101	Real Time TX bias current	
102-103	Real Time TX optical power	
104-105	Real Time RX received power	
106-109	Reserved	
110(bit7)	NA	
110(bit6)	NA	
110(bit5)	Reserved	
110(bit4)	NA	
110(bit3)	NA	
110(bit2)	Digital state of TX fault output pin	
110(bit1)	Digital state of LOS output pin	
110(bit0)	NA	
111	Reserved	
112(bit7)	Set when internal temperature exceeds high alarm level	
112(bit6)	Set when internal temperature exceeds is below alarm level	
112(bit5)	Set when internal supply voltage exceeds high alarm level	
112(bit4)	Set when internal supply voltage is below alarm level	
112(bit3)	Set when TX bias exceeds high alarm level	
112(bit2)	Set when TX bias voltage is below alarm level	
112(bit1)	Set when TX output power exceeds high alarm level	
112(bit0)	Set when TX output power voltage is below alarm level	
113(bit7)	Set when RX received power exceeds high alarm level	
113(bit6)	Set when RX received power is below alarm level	
113(bit5-0)	Reserved	
114-115	Reserved	
116(bit7)	Set when internal temperature exceeds high warning level	
116(bit6)	Set when internal temperature exceeds is below warning level	
116(bit5)	Set when internal supply voltage exceeds high warning level	
116(bit4)	Set when internal supply voltage is below warning level	
116(bit3)	Set when TX bias exceeds high warning level	
116(bit2)	Set when TX bias voltage is below warning level	
116(bit1)	Set when TX output power exceeds high warning level	
116(bit0)	Set when TX output power voltage is below warning level	
117(bit7)	Set when RX received power exceeds high warning level	
117(bit6)	Set when RX received power is below warning level	
117(bit5-0)	Reserved	
118-119	Reserved	
120-127	Reserved	

Dimensions

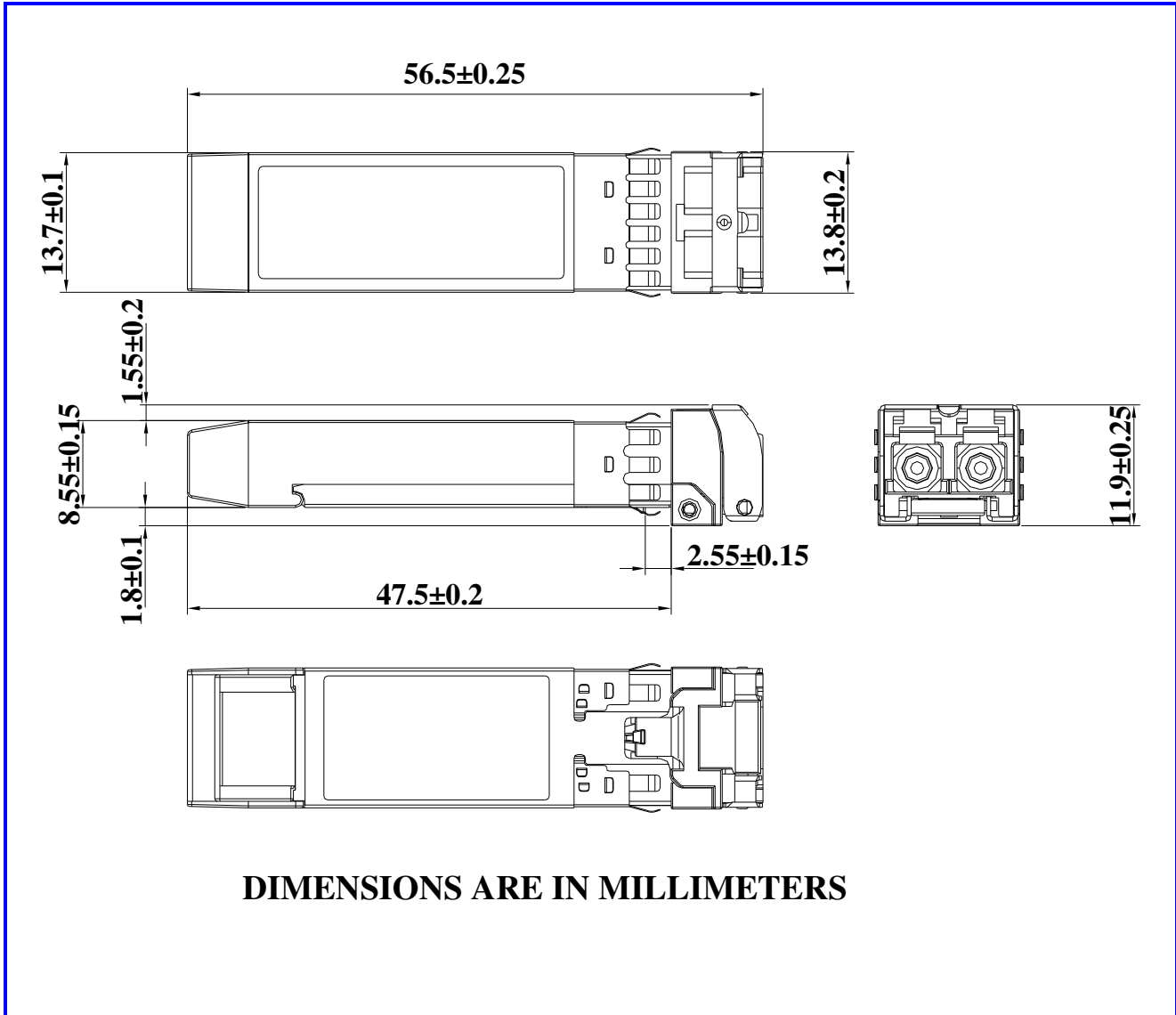

**DIMENSIONS ARE IN MILLIMETERS**

**SFP host board mechanical layout**

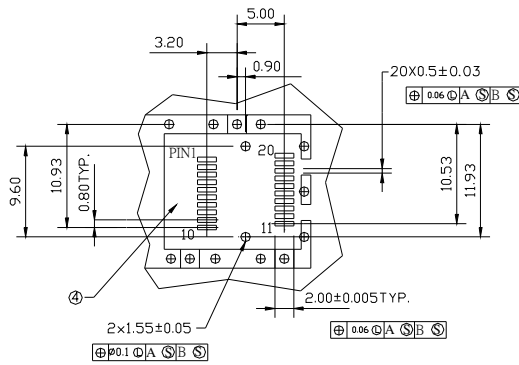
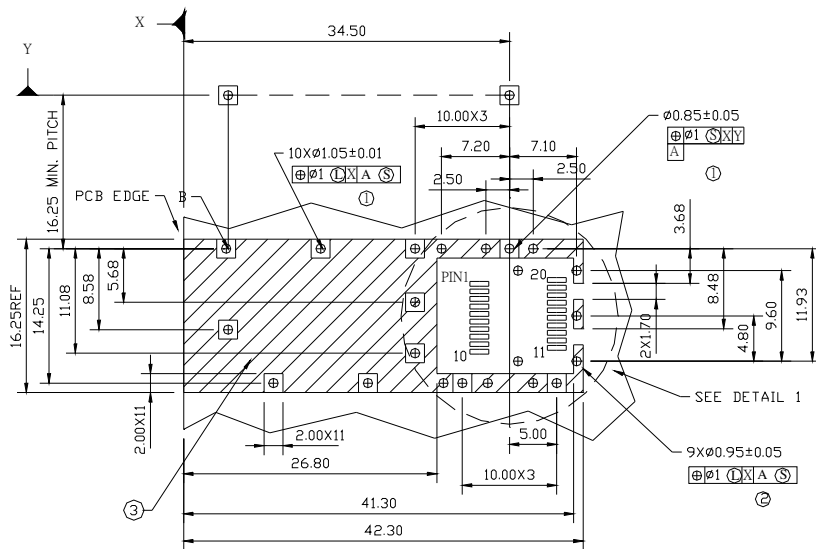

DETAIL 1

**LEGEND**

1. PADS AND VIAS ARE CHASSIS GROUND
2. THROUGH HOLES, PLATING OPTIONAL
3. HATCHED AREA DENOTES COMPONENT AND TRACE KEEPOUT (EXCEPT CHASSIS GROUND)
4. AREA DENOTES COMPONENT KEEPOUT (TRACES ALLOWED)

DIMENSIONS ARE IN MILLIMETERS

Unit: mm

Assembly drawing

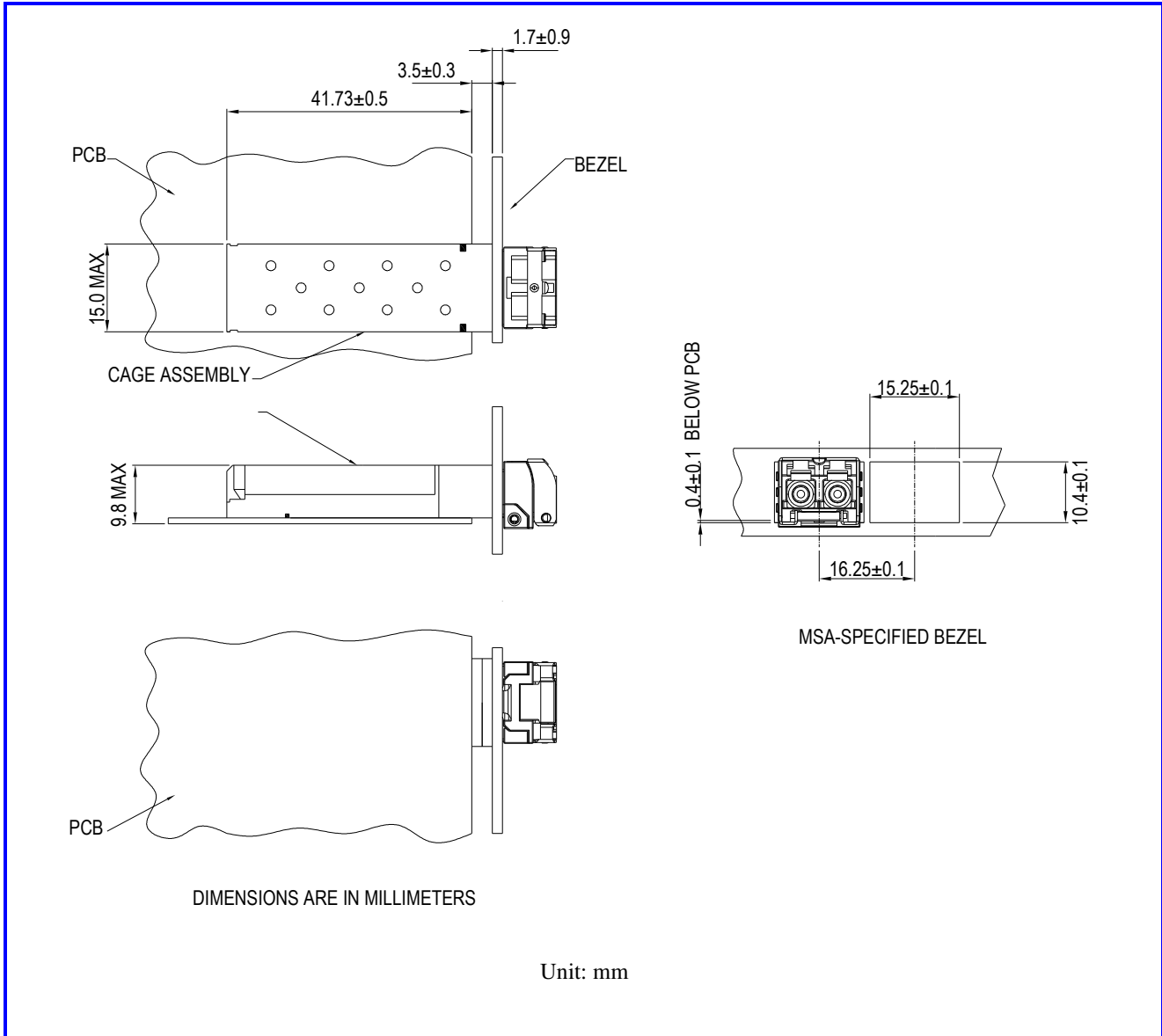

## Pin Assignment

Pin-Out

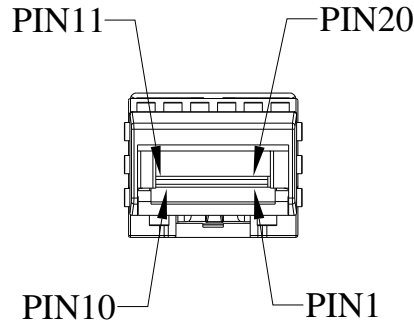

Pin	Signal Name	Description
1	$T_{GND}$	Transmit Ground
2	$TX\_FAULT$	Transmit Fault
3	$TX\_DISABLE$	Transmit Disable
4	$MOD\_DEF (2)$	SDA Serial Data Signal
5	$MOD\_DEF (1)$	SCL Serial Clock Signal
6	$MOD\_DEF (0)$	LVTTL Low
7	$RS0$	RX Rate Select, Not used
8	$RX\_LOS$	Receiver Loss of Signal, LVTTL High, open drain
9	$RS1$	TX Rate Select, Not used
10	$R_{GND}$	Receiver Ground
11	$R_{GND}$	Receiver Ground
12	$RX-$	Receive Data out Bar, ac coupled
13	$RX+$	Receive Data out, ac coupled
14	$R_{GND}$	Receiver Ground
15	$V_{CCR}$	Receiver Power Supply
16	$V_{CCT}$	Transmitter Power Supply
17	$T_{GND}$	Transmitter Ground
18	$TX+$	Transmit Data in, ac coupled
19	$TX-$	Transmit Data in Bar, ac coupled
20	$T_{GND}$	Transmitter Ground