

155Mbps ATM-Single Mode Transceiver

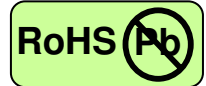

1×9 BIDI, Single SC Connector, 1550nm DFB LD for Single Mode Fiber, RoHS Compliant



Features

- 1550nm DFB LD
- Data Rate: 155Mbps, NRZ
- Single +3.3V or +5V Power Supply
- RoHS Compliant and Lead-free
- PECL Differential Electrical Interface
- Industry Standard 1×9 Output Footprint
- Single SC Connector
- Compliance with 100Base-FX of IEEE802.3u Standard
- Compliance with FDDI PMD Standard
- Compliance with ATM Standard
- Eye Safety
Designed to meet Laser Class 1 comply with EN60825-1

Applications

- Fast Ethernet
- FDDI
- ATM/SONET OC-3/SDH STM-1
- Single mode fiber links
- Optical-Electrical Interface Conversion

Description

The CT-0155TBR-Kx6C series from Coretek Opto Corp. are the high performance and cost-effective module for serial optical data communication applications specified for single mode of 155 Mb/s. It operates with +5V or +3.3V power supply. The module is intended for Single-mode fiber, operates at a nominal wavelength of Tx: 1550nm / Rx: 1310nm and complies with the industry standard 1x9 footprint. Each module consists of a bi-directional optical subassembly that combines a transmitter with a receiver and an electrical subassembly. All of them are housed in a plastic package and the combination produces a reliable component.

The module is a single fiber connector transceiver designed to use in fast Ethernet applications and provide an ATM/SONET OC-3/SDH STM-1 compliant link for 155 Mb/s long reach applications. The characteristics are performed in accordance with Telcordia Specification GR-468-CORE.

EMC

Most equipment utilizing high-speed transceivers will be required to meet the following requirements:

- 1) FCC in the United States
- 2) CENELEC EN55022 (CISPR 22) in Europe

To assist the customer in managing the overall equipment EMC performance, the transceivers have been designed to satisfy FCC class B limits and provide good immunity to radio-frequency electromagnetic fields.

Eye Safety

The transceivers have been designed to meet Class 1 eye safety and comply with EN 60825-1.

155Mbps ATM-Single Mode Transceiver



Product Information

Model Number	Operating Voltage & SD Output	Distance	Wavelength	Output Power	Sensitivity
CT-0155TBR-K16C	5V PECL DC/DC	40 km	1550 nm DFB / 1310 nm	-8 ~ -3 dBm	≤ -34 dBm
CT-0155TBR-K26C	3.3V PECL DC/DC				

ABSOLUTE MAX RATINGS

PARAMETER	SYMBOL	MIN	MAX	UNIT	NOTE
Storage Temperature	T _S	-40	85	°C	
Supply Voltage	V _{CC}	0	6	V	
Lead Soldering Temperature/Time	T _{SOLD}		260	°C	10 sec on lead
Data Input Voltage	---	0	V _{CC}	V	

OPERATING CONDITIONS

PARAMETER	SYMBOL	MIN.	TYP.	MAX.	UNIT	NOTE
Ambient Operating Temperature	T _A	0		70	°C	
Supply Voltage (for 5.0V)	V _{CC}	4.75		5.25	V	
Supply Voltage (for 3.3V)	V _{CC}	3.10		3.50	V	

ELECTRICAL CHARACTERISTICS

PARAMETER	SYMBOL	MIN	MAX	UNIT	NOTE
Transmitter					
Transmitter Supply Current	I _{CC}		200	mA	
Transmitter Data Input Current – Low	I _{IL}	-350		μA	
Transmitter Data Input Current – High	I _{IH}		350	μA	
Transmitter Data Input Voltage – Low	V _{IL} -V _{CC}	-1.810	-1.620	V	1
Transmitter Data Input Voltage – High	V _{IH} -V _{CC}	-1.025	-0.880	V	1
Receiver					
Receiver Supply Current	I _{CC}		100	mA	
Receiver Data Output Voltage – Low	V _{OL} -V _{CC}	-1.810	-1.620	V	2
Receiver Data Output Voltage – High	V _{OH} -V _{CC}	-1.025	-0.880	V	2
Signal Detect Output Voltage – Low	V _{OL} -V _{CC}	-1.810	-1.620	V	2
Signal Detect Output Voltage – High	V _{OH} -V _{CC}	-1.025	-0.880	V	2

TRANSMITTER ELECTRO-OPTICAL CHARACTERISTICS

PARAMETER	SYMBOL	MIN	TYP.	MAX	UNIT	NOTE
Optical Output Power	P _O	-8		-3	dBm	3
Extinction Ratio	ER	10			dB	
Center Wavelength	λ _c	1530	1550	1570	nm	
Spectral Width (-20dB)	Δλ			1	nm	
Side Mode Suppression Ratio	SMSR	30			dB	
Optical Rise time (10%-90%)	t _r			2.0	ns p-p	4
Optical Fall time (10%-90%)	t _f			2.0	ns p-p	4
Output Eye						Compliant with ITU recommendation G.957

155Mbps ATM-Single Mode Transceiver



RECEIVER ELECTRO-OPTICAL CHARACTERISTICS

PARAMETER	SYMBOL	MIN	TYP.	MAX	UNIT	NOTE
Maximum Input Optical Power	P_{max}	-3			dBm	5
Receiver Sensitivity	P_{min}			-34	dBm	5
Operating Wavelength	λ	1270	1310	1350	nm	
Signal Detect - Asserted	P_A			-34	dBm	6
Signal Detect - Deasserted	P_D	-47			dBm	7
Signal Detect - Hysteresis	$P_A - P_D$	0.5		4	dB	

Notes:

1. Compatible with 10K, 10KH, 100K ECL and PECL output signals.
2. These outputs are compatible with 10K, 10KH, 100K ECL and PECL inputs.
3. Measured average power coupled into 9/125 μ m single mode fiber.
4. The input data pattern is a 12.5MHz square wave pattern.
5. Measured with $2^{23}-1$ PRBS at BER< 10^{-10}
6. Measured on transition – low to high
7. Measured on transition – high to low

BLOCK DIAGRAM OF TRANSCEIVER

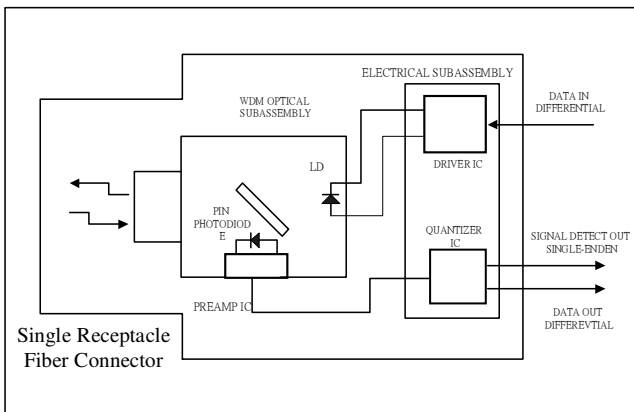

PIN OUT DIAGRAM OF TRANSCEIVER

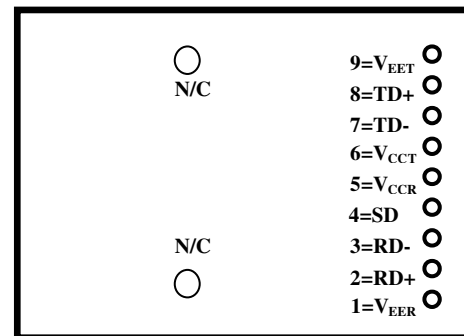

PIN OUT TABLE

Pin	Symbol	Functional Description
Mounting Posts		
The mounting posts are provided for transceiver mechanical attachment to the circuit board. They should not be connected to the circuit ground but can be connected to the chassis ground.		
1	V_{EER}	Receiver Signal Ground
2	RD+	Receiver Data Non-inverted Differential Output
3	RD-	Receiver Data Inverted Differential Output
4	SD	Signal Detect is a PECL output. A high level indicates a received optical signal
5	V_{CCR}	Receiver Power Supply
6	V_{CCT}	Transmitter Power Supply
7	TD-	Transmitter Data Inverted Differential Input
8	TD+	Transmitter Data Non-inverted Differential Input
9	V_{EET}	Transmitter Signal Ground

155Mbps ATM-Single Mode Transceiver



RECOMMENDED CIRCUIT SCHEMATIC

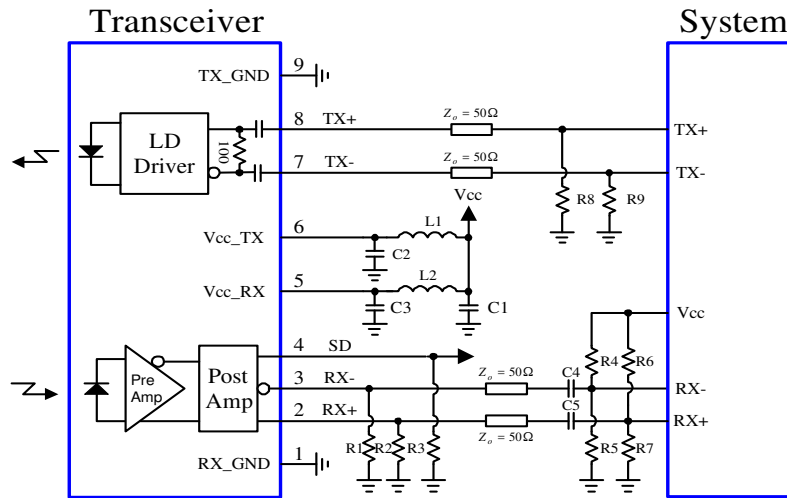

$C1 = 4.7 \mu F$ $L1/L2 = 1 \mu H$ $C2/C3/C4/C5 = 0.1 \mu F$
 $R1/R2 = 150 \Omega$ (3.3V) $R3 = 270 \Omega$ (3.3V)
 $R1/R2 = 300 \Omega$ (5V) $R3 = 510 \Omega$ (5V)
 $R4, R5, R6, R7, R8, R9$ depend on System chip

MECHANICAL DIMENSIONS

Units in mm

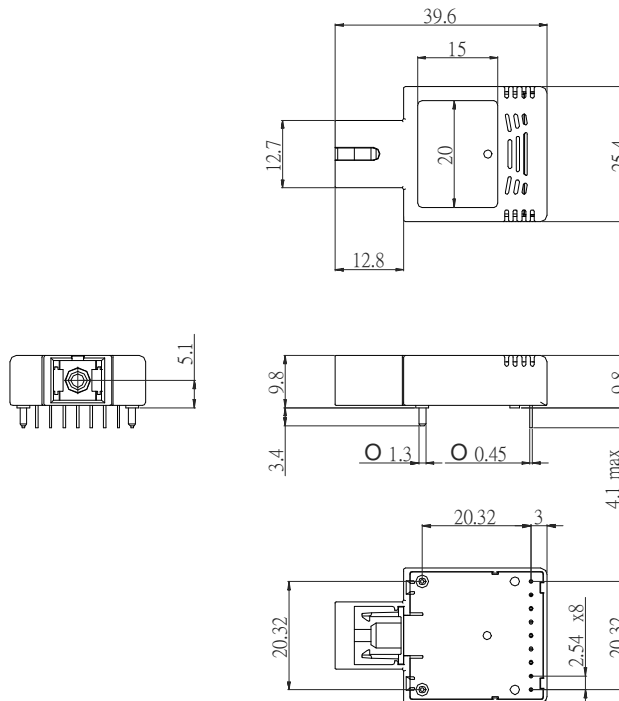

Claim:

CORETEK Opto Corp. reserves the right to make changes in the specification described hereinafter without prior notice.