



Features

- 100M/1G/2.5G/5Gbps Links up to 100m using Cat5e Cable
- 10Gbps Links up to 30m using Cat7 Cable
- Low Power Consumption
3.0W Max, 30m @ 10Gbps, 70°C
3.0W Max, 100m @ 100M, 1G, 2.5G and 5Gbps, 70°C
- IEEE 802.3az/bz Compliant
- SFF-8431 and SFF-8432 MSA Compliant
- Access EEPROM/PHY IC via 2-wire Serial Bus
- I2C to MDIO Bridge (Support IEEE 802.3 Clause 45)
- Fast Retrain and EMI Cancellation Algorithm
- Compliant with RoHS.
- +3.3V Single Power Supply
- Temperature Range 0°C to +70°C & -40°C to +85°C

Application

- 10Gbps Ethernet over Category 7 Cable
- 5Gbps Ethernet over Category 5e/6a Cable
- Distributed multi-processing
- High speed I/O for file server or high-end workstation
- Switch/Router to Switch/Router Link

Description

ASFP-TNBT Copper SFP transceiver acts as physical layer function of 100M/1G/2.5G/5Gbps Ethernet using Cat5e, Cat6a twisted-pair cable and 10Gbps Ethernet using cat7. It also supports auto-negotiation with any 100M/1G/2.5G/5/10Gbps link partner. The Copper SFP transceiver is designed fully compliant with IEEE 802.3 standard and connects to network through isolated transformer. It can be programmed to fix operating speed or auto-negotiation with advertised capabilities.

ASFP-TNBT Copper SFP transceiver features simple application in data center network at 5Gbps and allows link up 100 meters. It really enables a new dimension of flexibility for Network Equipment designer or data center facility planner to optimize capital expense.

ASFP-TNBT Copper SFP transceiver provides standard serial ID information compliant with SFP MSA, which can be accessed with address of 0xA0 via the 2-wire serial CMOS EEPROM protocol. The physical IC can be also accessed via 2-wire serial bus at address 0xAC for a write and 0xAD for a read. Detail protocol refers to "I2C to MDIO Bridge" section.



NBASE-T Copper Transceiver
Small Form Factor Pluggable (SFP+), 3.3V
100M/1G/2.5G/5G/10Gbps Ethernet

Ordering Information

PART NUMBER	Product Name
ASFPT-TNBT-C-NA	NBASE-T Copper SFP, 0~70C
ASFPT-TNBT-I-NA	NBASE-T Copper SFP, -40~85C

Absolute Maximum Ratings

PARAMETER	SYMBOL	MIN	MAX	UNITS	NOTE
Storage Temperature	T_s	-45	90	°C	
Storage Humidity	H_s	5	90	%	

Recommended Operating Conditions

PARAMETER	SYMBOL	MIN	MAX	UNITS	NOTE
Operating Temperature	T	0	70	°C	Case Temperature -40~85C for ASFPT-TNBT-I-NA
Operating Humidity	H_o	10	85	%	
Supply Voltage	V_{cc}	3.135	3.465	V	Typ. 3.3V
Surge Current	I_{surge}		30	mA	Hot Plug

Cable Length Operating Conditions

PARAMETER	SYMBOL	MAX		UNITS	NOTE
		0~70C	-40~85C		
10Gbps @30M Cat7	I	900	1200	mA	(1), (2), (4)
5Gbps @100M Cat5e	I	900	1200	mA	(1), (2), (4)
2.5Gbps @100M Cat5e	I	900	1200	mA	(1), (3)
1Gbps @100M Cat5e	I	900	1200	mA	(1), (2)
100Mbps @100M Cat5e	I	900	1200	mA	(1), (2)

Note:

- (1) Chamber = 60°C, measurement after traffic 30 minutes without packet loss.
- (2) Single Cat5e 100m cable without series.
- (3) Two Cat5e 100m cable with series.
- (4) Case temperature measurement is around chamber temperature + 22~23°C.
Thus, ambient temperature should be controlled under 50°C for proper operation.
Network switch with good air flow/temperature control at 25°C, case temperature should be less than 50°C.



NBASE-T Copper Transceiver
Small Form Factor Pluggable (SFP+), 3.3V
100M/1G/2.5G/5G/10Gbps Ethernet

Electrical Characteristics

PARAMETER	SYMBOL	MIN	TYP.	MAX	UNITS	NOTE
Transmitter						
Data Input differential Voltage	$V_{D, TX}$	110		1000	mV	(1)
Differential Input Impedance	Z_{TX}		100		Ohm	
Transmitter Disable Input-High	V_{Dish}		N/A		V	Not implement
Transmitter Disable Input-Low	V_{DISL}		N/A		V	Not implement
Receiver						
Data Output Differential Voltage	$V_{D, RX}$	370		800	mV	(3)
Differential Output Impedance	Z_{RX}		100		Ohm	
LOS Output Voltage – High	V_{SDHL}	2.4		V_{cc}	V	(2)
LOS Output Voltage – Low	V_{SDL}	0		0.5	V	(2)

Note:

- (1) Internally AC coupled to PHY chip.
- (2) Pull up to VCC with a 4.7K – 10K Ohm resistor on host Board
- (3) Internally AC coupled, but requires a 100 Ohm differential termination at MAC side.

Block Diagram of Transceiver

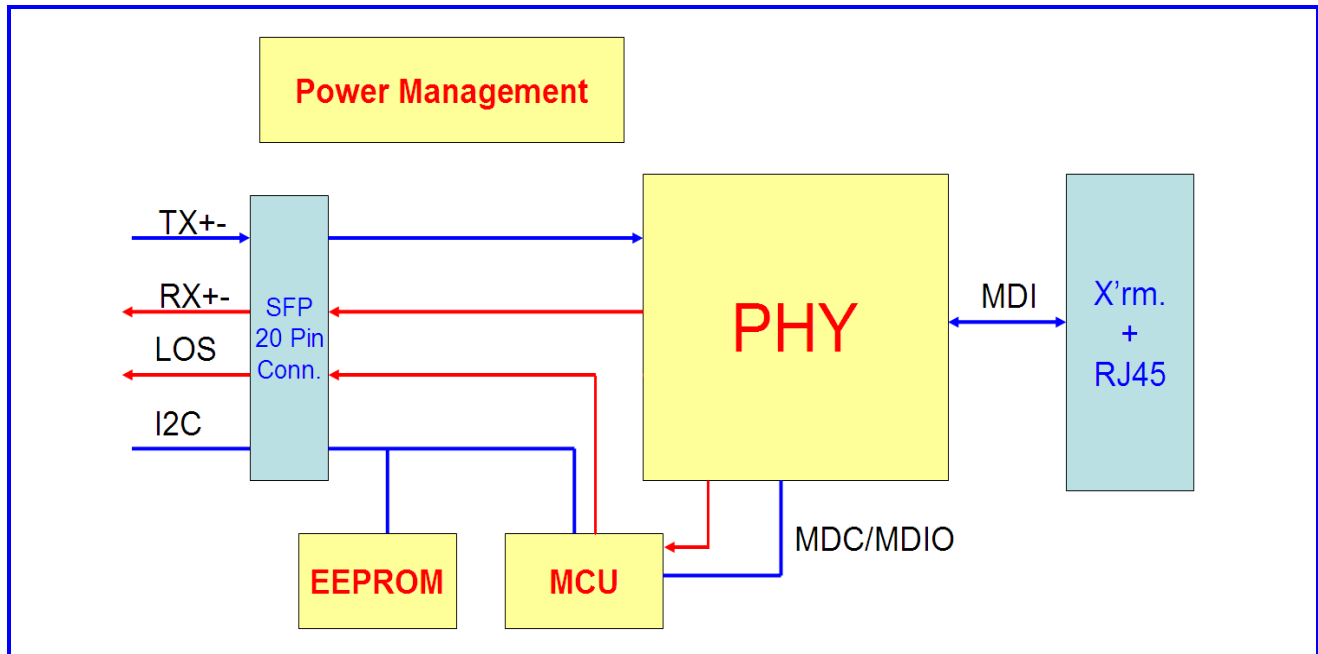

LOS Function

The SFP MSA specification defines a pin called LOS to indicate loss of signal to the motherboard. This should be pulled up with a 4.7K to 10K resistor. Pull up voltage between 2.0V and $V_{cc-T/R}+0.3V$. When high, this output indicates link fail. Low indicates normal operation. In the low state, the output will be pulled to $<0.5V$.

Termination Circuits

Inputs to the transceiver are AC coupled and internally terminated through 50 ohms. The input signal must have at least an 110mV differential peak-to-peak signal swing. Output from the receiver section of the module is also AC coupled and is expected to drive a 50 ohm load. Different termination strategies may be required depending on the particular Serializer/Deserializer chip set used. The transceiver is designed with AC coupled data inputs and outputs to provide the following advantages:

Close positioning of SERDES with respect to transceiver; allows for shorter line lengths and at high speeds reduces EMI. Minimize number of external components. Internal termination reduces the potential for un-terminated stubs which would otherwise increase jitter and reduce transmission margin.

Subsequently, this affords the customer capability to optimally locate the SERDES as close to the transceiver as possible and save valuable real estate.

Power Coupling

A suggested layout for power and ground connections is given in Figure 1 below. Connections are made via separate voltage and ground planes. The mounting posts are at case ground and should not be connected to circuit ground. The ferrite bead should provide a real impedance of 50 to 100 ohms at 100 to 1000 MHz. Bypass capacitors should be placed as close to the 20 pin connector as possible.

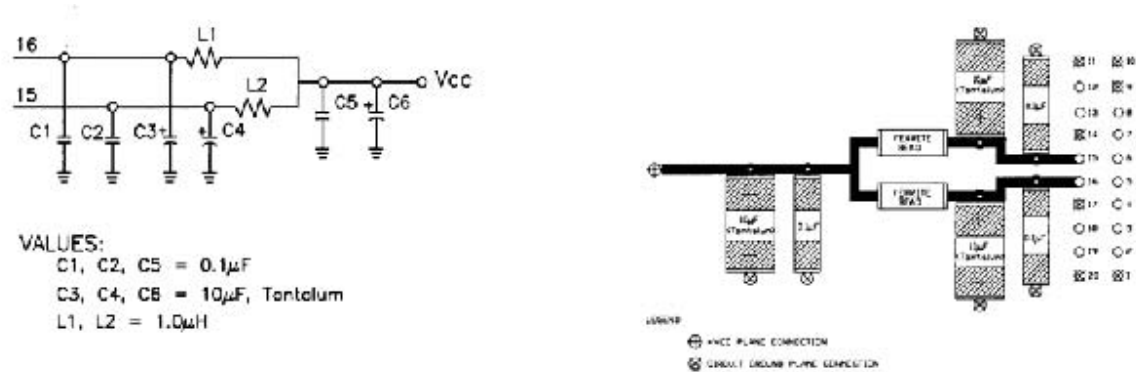

Figure 1: Suggested Power Coupling

Serial Communication Protocol

APAC ASFPT-TNBT supports the 2-wire serial communication protocol defined in the SFP MSA. This SFP uses a 256 bytes EEPROM with an address of 0xA0. The physical layer IC can also be accessed via the 2-wire serial bus at address 0xAC/0xAD. See “I2C to MDIO Bridge” section.



**NBASE-T Copper Transceiver
Small Form Factor Pluggable (SFP+), 3.3V
100M/1G/2.5G/5G/10Gbps Ethernet**

EEPROM Serial ID Memory Contents

Accessing Serial ID Memory uses the 2 wire address 10100000 (A0H). Memory Contents of Serial ID are shown in Table 1.

Table 1 Serial ID Memory Contents

Addr.	Size (Bytes)	Name of Field	Hex	Description
0	1	identifier	03	SFP or SFP+
1	1	Ext.Identifier	04	GBIC/SFP function is defined by two-wire interface ID only
2	1	Connector	22	RJ45
3-10	8	Transceiver	XX XX XX XX XX XX	Transceiver Code
11	1	Encoding	00	
12	1	BR(Nominal)	64	10Gbps
13	1	Rate Identifier	00	Unspecified
14	1	Length(SMFm)-km	00	N/A
15	1	Length(SMF)	00	N/A
16	1	Length(50µm)	00	N/A
17	1	Length(62.5µm)	00	N/A
18	1	Length(cable)	64	100(units of meters)
19	1	Length(OM3)	00	N/A
20-35	16	Vendor name	XX XX XX XX XX XX XX 20 20 20 20 20 20 20 20	Vendor name (ASCII)
36	1	Transceiver	1C	10GBASE-T Short Reach (30 meters)
37-39	3	Vendor OUI	XX XX XX	Vendor OUI
40-55	16	Vendor PN	XX XX XX XX XX XX XX XX XX XX XX XX XX XX XX XX	Transceiver part number
56-59	4	Vendor rev	XX XX XX XX	Vendor rev
60-61	2	Wavelength	00	0nm
62	1	Unallocated	00	Unallocated
63	1	CC_BASE	Check Sum (Variable)	Check code for Base ID Fields
64-65	2	Options	00 02	RATE_SELECT functionality is implemented
66	1	BR	00	max
67	1	BR	00	min
68-83	16	Vendor SN	41 34 32 30 33 30 30 34 20 20 20 20 20 20 20	Serial Number of transceiver (ASCII). For example "A4203004".
84-91	8	Date code	XX XX XX XX XX XX XX XX	Manufacture date code
92	1	Diagnostic Monitoring Type	00	N/A
93	1	Enhanced Options	00	N/A
94	1	SFF-8472 Compliance	00	Digital diagnostic function not included or undefined
95	1	CC_EXT	Check Sum (Variable)	Check sum for Extended ID Field.
96-127	32	Vendor Specific	Read only	Depends on customer information

Note: The "XX" byte should be filled in according to practical case. For more information, please refer to the related document of SFP Multi-Source Agreement (MSA).



**NBASE-T Copper Transceiver
Small Form Factor Pluggable (SFP+), 3.3V
100M/1G/2.5G/5G/10Gbps Ethernet**

I2C to MDIO Bridge

ASFPT-TNBT has MCU inside to bridge host I2C to communicate with PHY MDIO interface. The I2C at slave address 0xAC for a write and 0xAD for a read.

MDIO write sequence : 6 bytes I2C frame are required.

- 1st byte : 0xAC (8bits)
- 2nd byte : 0b'000 + DEVAD (5 bits)
- 3~4 bytes : Register Address (16 bits)
- 5~6 bytes : Write Data (16 bits)

MDIO read sequence : 7 bytes I2C frame are required.

- 1st byte : 0xAC (8bits)
- 2nd byte : 0b'001 + DEVAD (5 bits)
- 3~4 bytes : Register Address (16 bits)

Delay >1 mS (Important: for MCU access PHY through MDIO)

- 5th byte : 0xAD (8bits)
- 6~7 bytes : Read Data (16 bits)

Example:

Write 0x03C0 to DEVAD 1 Register 0xF400																		
S	1	0	1	0	1	1	0	0	ACK	0	0	0	0	0	0	0	1	ACK
	1	1	1	1	0	1	0	0	ACK	0	0	0	0	0	0	0	0	ACK
	0	0	0	0	0	0	1	1	ACK	1	1	0	0	0	0	0	0	ACK
																		P
Read 0x002B from DEVAD 1 Register 0x0002																		
S	1	0	1	0	1	1	0	0	ACK	0	0	1	0	0	0	0	1	ACK
	0	0	0	0	0	0	0	0	ACK	0	0	0	0	0	0	0	1	ACK
	Delay > 1mS for MCU access PHY MDIO																	
S	1	0	1	0	1	1	0	1	ACK	0	0	0	0	0	0	0	0	ACK
	0	0	1	0	1	0	1	1	NAK	P								
	Master		Slave		S	Start		P	Stop									

Connection Diagram

Pin-Out

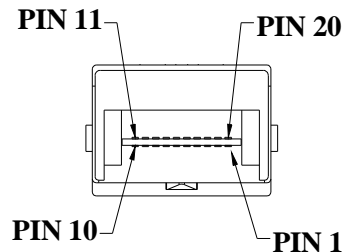

Pin	Signal Name	Function	NOTES
1	VeeT	Transmitter Ground	VeeT and VeeR are connected in SFP.
2	TX_FAULT	Transmitter Fault Indication	Not Implemented. Tied to VeeT in SFP.
3	TX_DISABLE	Transmitter Disable	Not Implemented. Floating in host.
4	MOD DEF (2)	Module Definition 2	Data Line for Serial ID.
5	MOD DEF (1)	Module Definition 1	Clock Line for Serial ID.
6	MOD DEF (0)	Module Definition 0	Tied to Vee in SFP.
7	RATE SELECT	Not Implemented	Not implemented.
8	LOS	Loss of Signal	See LOS option.
9	VeeR	Receiver Ground	VeeT and VeeR are connected in SFP.
10	VeeR	Receiver Ground	VeeT and VeeR are connected in SFP.
11	VeeR	Receiver Ground	VeeT and VeeR are connected in SFP.
12	RD-	Inverted Received Data out	AC coupled 100 ohm differential high speed data lines.
13	RD+	Non-Inverted Received Data out	AC coupled 100 ohm differential high speed data lines.
14	VeeR	Receiver Ground	VeeT and VeeR are connected in SFP.
15	VccR	Receiver Power	VccR and VccT are connected in SFP.
16	VccT	Transmitter Power	VccR and VccT are connected in SFP.
17	VeeT	Transmitter Ground	VeeT and VeeR are connected in SFP.
18	TD+	Non-inverted Data In	AC coupled 100 ohm differential high speed data lines.
19	TD-	Inverted Data In	AC coupled 100ohm differential high speed data lines
20	VeeT	Transmitter Ground	Veet and VeeR are connected in SFP



**NBASE-T Copper Transceiver
Small Form Factor Pluggable (SFP+), 3.3V
100M/1G/2.5G/5G/10Gbps Ethernet**

Notes:

1. TX Fault is not used and is always tied to ground.
2. TX Disable as described in the MSA is not applicable to the copper SFP module.
3. Mod-Def 0,1, 2. These are the module definition pins. They should be pulled up with a 4.7-10 K resistor on the host board to a supply less than $VCCT + 0.3\text{ V}$ or $VCCR + 0.3\text{ V}$.
4. RD-/+ : These are the differential receiver outputs. They are AC coupled 100 Ohm differential lines which should be terminated with 100 ohm differential at the user SerDes. The AC coupling is done inside the module and is thus not required on the host board.
5. VCCR and VCCT are the receiver and transmitter power supplies. They are defined as $3.3\text{ V} \pm 5\%$ at the SFP connector pin.
6. TD-/+ : These are the differential transmitter inputs. They are AC coupled differential lines with 100 Ohm differential termination inside the module. The AC coupling is done inside the module and is thus not required on the host board.

Drawing Dimensions

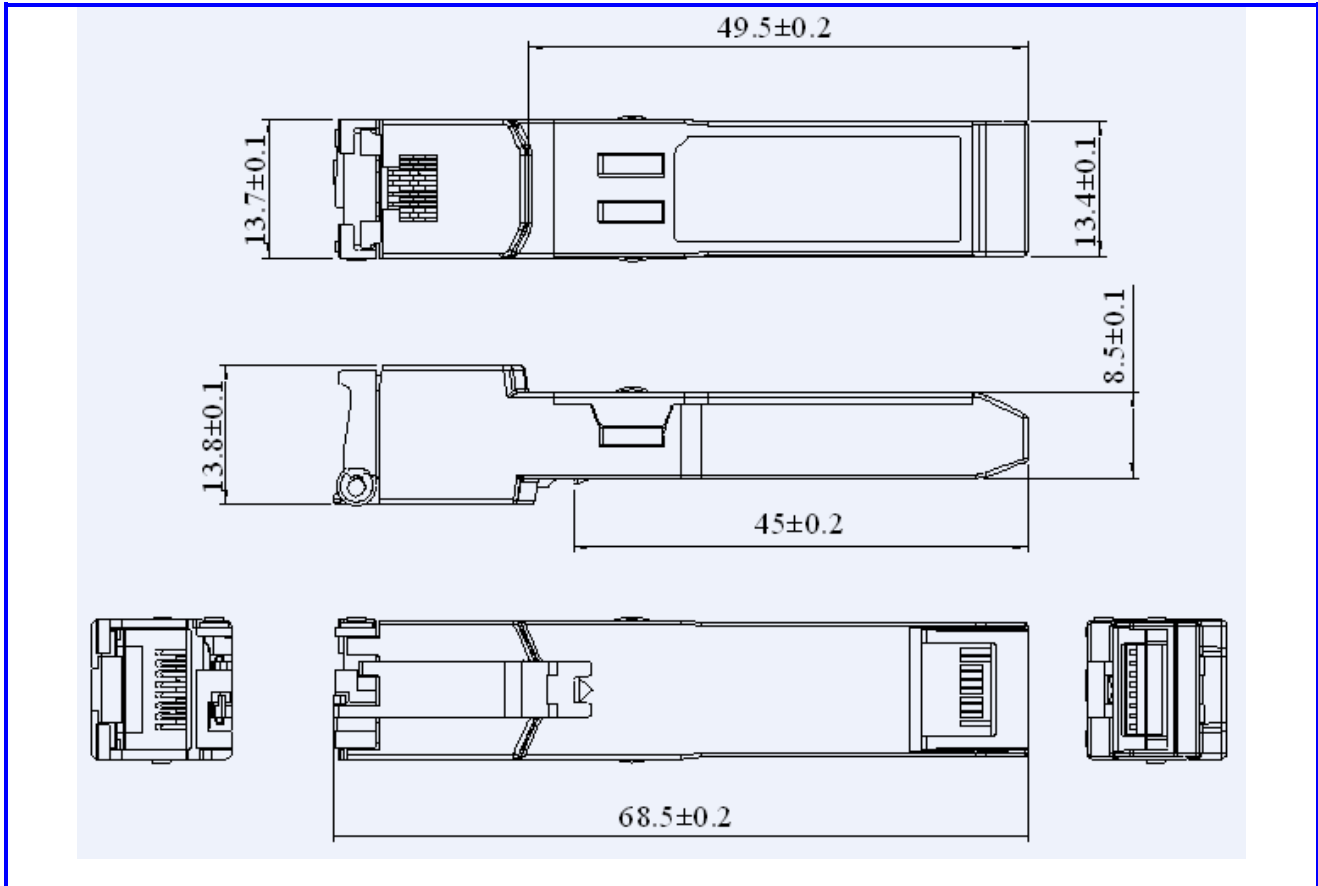

Mating of SFP Transceiver to SFP Host Board Connector

The pads on the PCB of the SFP transceiver shall be designed for a sequenced mating as follows: First mate: Ground contacts. Second mate: Power contacts. Third mate: Signal contacts The SFP MSA specification for a typical contact pad plating for the PCB is 0.38 micrometers minimum hard gold over 1.27 micrometers minimum thick nickel. To ensure the long term reliability performance after a minimum of 50 insertion removal cycles, the contact plating of the transceiver is 0.762 micron (30 micro-inches) over 3.81 micron (150 micro-inches) of Ni on Cu contact pads.

RJ45 Connector

RJ45 connector shall support shielded and unshielded cables. Also, the connector is mechanically robust enough and designed to prevent loss of link, when the cable is positioned or moves in different angles. The connector shall pass the “wiggle” RJ45 connector operational stress test. During the test, after the cable is plugged in, the cable is moved in circle to cover all 360 deg in the vertical plane, while the data traffic is on. There shall be no link or data loss.